

DATE :	Nov/20/09'
CMS P/N :	B0106050
Dwg NO. :	A05759
CUST. P/N :	1394C-9ARS-9ARS-200-00
CUSTOMER :	
DESCRIPTION	1394C-9ARS-9ARS-200-00
APPROVE:	

REV.	DATE	DESCRIPTION	BY
1.0	Nov/20/09'	D2250	Catherine

## CONFIGURATION



END A

END B

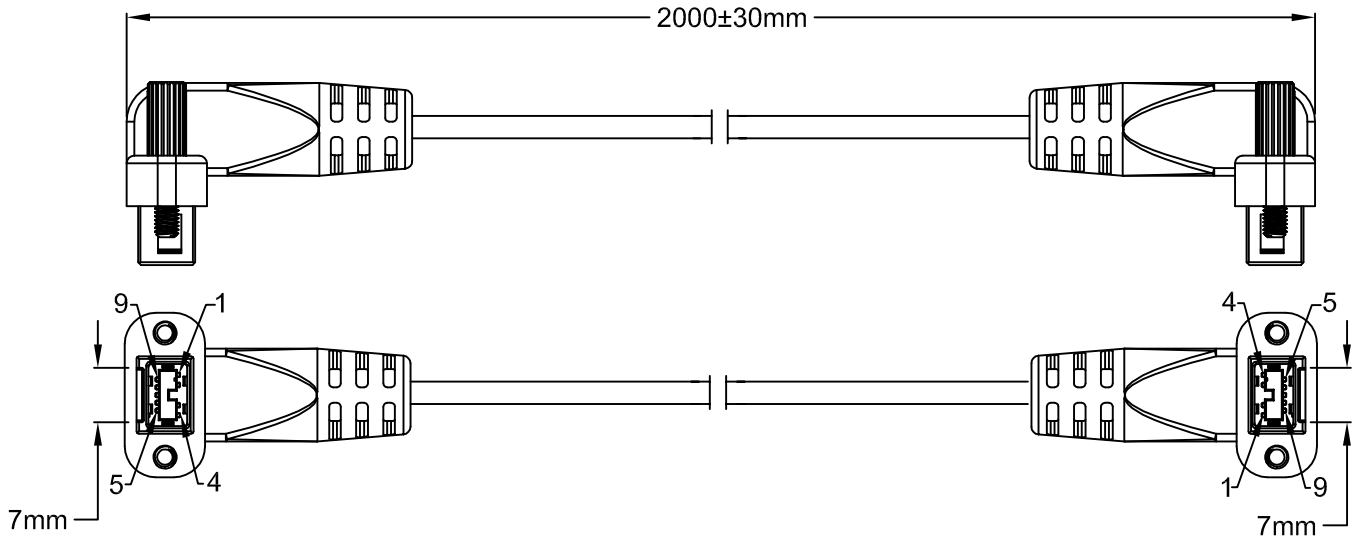

## SPECIFICATION OF MATERIAL

### 1. END A

CONT. PLATING	Gold 30u"	MOLD No.	CMS-1394b13	SHIELD'G	-
CONNECTOR TYPE	HSP-AM013500			T. SCREW	Jack Screw #4-40UNC Size: 5.0x20.0x4.5mm

### 2. END B

CONT. PLATING	Gold 30u"	MOLD No.	CMS-1394b13	SHIELD'G	-
CONNECTOR TYPE	HSP-AM013500			T. SCREW	Jack Screw #4-40UNC Size: 5.0x20.0x4.5mm

### 3. WIRES

WIRE GAUGE	22Awg & 25Awg	LENGTH	2000+20-0mm	SHIELD'G	MAB
CONDUCTORS	2C+(1TP+MAE)x2	COLOR	Grey 006	UL/CSA	UL20379
JACKET MAT'L	PVC	INS. MAT'L	SR PVC&FM-PE	WIRE O.D.	7.0mm

### 4. CONNECTOR PIN OUT

### 5. SPECIAL REQUIREMENTS

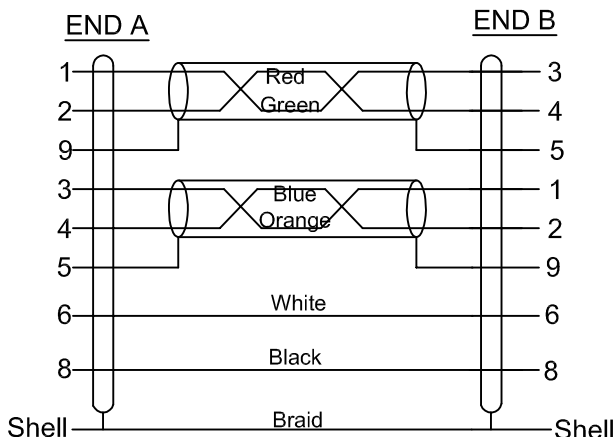

- 5.1 Product requirement for Green environment protection:RoHS.
- 5.2 Overmold PVC : 65P,Black (RoHS).

**\* Standard Product**